



1. 基本特性

- ROM: 1024 字节 OTP ROM
- RAM: 25 字节
- 76 个单字指令
- 堆栈级别: 2
- I/O 口: 13
 - B 口: 8 个上拉 I/O 脚位
 - A0~3 口: 4 个标准 I/O 脚位
 - RTCC/PA4: 输入脚位
- 四种外部振荡模式可选择: RC, LS (低速) 晶振, NS (标准速度) 晶振, HS (高速) 晶振
- B 口有信号触发唤醒功能
- 内置 8 位累加定时器/计数器带 8 位可编程预分频器
- 内置看门狗定时器
- 工作电压: 2.2V~5.5V
- 不同的封装方式:
 - MK7A10PSS20C: SSOP 20 脚位
 - MK7A10PD18C: DIP 18 脚位
 - MK7A10PS18C: SOP 18 脚位
 - MK7A10PD14C: DIP 14 脚位
 - MK7A10PS14C: SOP 14 脚位



2. 脚位分配

2.1 18 Pin & 20 Pin

PA2	1	●	18	PA1
PA3	2		17	PA0
RTCC	3		16	OSC1
~RESET	4		15	OSC2
VSS	5		14	VDD
PB0	6		13	PB7
PB1	7		12	PB6
PB2	8		11	PB5
PB3	9		10	PB4

18 脚 DIP 或 SOP 封装

PA2	1	●	20	PA1
PA3	2		19	PA0
RTCC	3		18	OSC1
~RESET	4		17	OSC2
VSS	5		16	VDD
VSS	6		15	VDD
PB0	7		14	PB7
PB1	8		13	PB6
PB2	9		12	PB5
PB3	10		11	PB4

20 脚 SSOP 封装

2.2 14 Pin

RTCC	1	●	14	OSC1
~RESET	2		13	OSC2
VSS	3		12	VDD
PB0	4		11	PB7
PB1	5		10	PB6
PB2	6		9	PB5
PB3	7		8	PB4

14 脚 DIP 及 SOP 封装



3. 脚位描述

名称	I/O	描述
RTCC	I	1. 外部时钟或脉冲输入到 TMR0 计数器 2. PA4 输入 (当 config. Bit6 设置为 1 时)
PA3~0	I/O	I/O 口 A0~3
PB7~0	I/O	1. I/O 口 B0~7 2. 信号触发唤醒 (当 config. Bit7 设置为 1 时) 3. 上拉电阻 (当 config. Bit7 设置为 1 时)
RESETB	I	系统复位信号
OSC1	I	振荡器输入
OSC2	O	振荡器输出
VDD	P	系统电源
VSS	P	接地

<注> I: 输入; O: 输出; I/O: 输入/输出; P: 电源

4. 系统图表

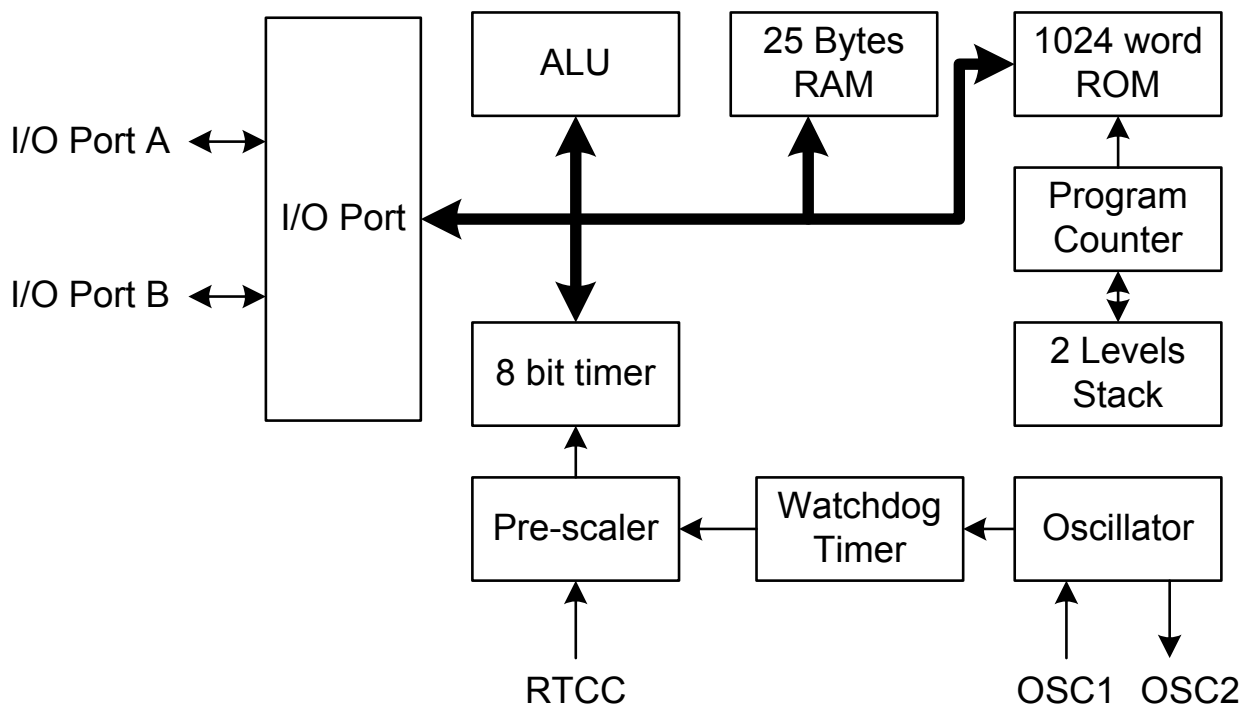



5. 存储器映象

5.1 程序存储器

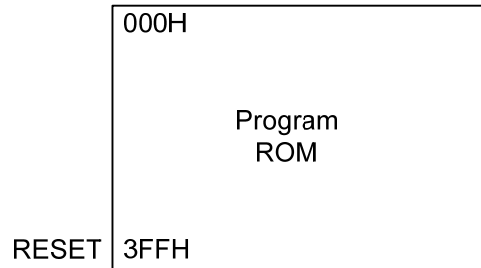

< 注 > LCALL 和 LGOTO 允许直接在 1K 字节的地址内选址。

5.2 控制寄存器

Name	Addr	Bit 7	Bit 6	Bit 5	Bit 4	Bit 3	Bit 2	Bit 1	Bit 0
CONFIG		TYPE	RTCE	LV1	LV0	CPT	WDTE	FOSC1	FOSC0
SELECT		X	X	SUR0	EDGE0	PSA	PS2	PS1	PS0
IAR	\$00	X	X	X	A4	A3	A2	A1	A0
TMR0	\$01	D7	D6	D5	D4	D3	D2	D1	D0
PC	\$02	D7	D6	D5	D4	D3	D2	D1	D0
STATUS	\$03	X	X	SA0	TOB	PDB	Z	DC	C
BSR	\$04	X	X	X	D4	D3	D2	D1	D0
I/O Port _A	\$05	X	X	X	X	PA3	PA2	PA1	PA0
I/O Port _B	\$06	PB7	PB6	PB5	PB4	PB3	PB2	PB1	PB0

< 注 > X: 保留的



5.3 结构寄存器

Name	Bit 7	Bit 6	Bit 5	Bit 4	Bit 3	Bit 2	Bit 1	Bit 0
CONFIG	TYPE	RTCE	LV1	LV0	CPT	WDTE	FOSC1	FOSC0

Bit 1	Bit 0	OSC 类型	频率范围
0	0	LS (低速)	32~200KHz
0	1	NS (标准速度)	200K~10MHz
1	0	HS (高速)	10~20MHz
1	1	RC	32K~10MHz

Bit 2	描 述
0	看门狗定时器不允许
1	看门狗定时器允许

Bit 3	描 述
0	密码保护 开
1	密码保护 关

Bit 5	Bit 4	检测电压标准
0	0	4V
0	1	No use
1	0	2V
1	1	No use

Bit 6	描 述
0	只定时器输入
1	PA4 输入



Bit 7	描 述
0	B 口无信号触发唤醒功能
1	B 口有信号触发唤醒功能

<注> 当 B 口处于输入模式时，上拉电阻有效。

5.4 选择寄存器

Name	Bit 7	Bit 6	Bit 5	Bit 4	Bit 3	Bit 2	Bit 1	Bit 0
SELECT			SUR0	EDGE0	PSA	PS2	PS1	PS0

Bit 2	Bit 1	Bit 0	描 述	
PS2	PS1	PS0	TMR0 比率	WDT 比率
0	0	0	1:2	1:1
0	0	1	1:4	1:2
0	1	0	1:8	1:4
0	1	1	1:16	1:8
1	0	0	1:32	1:16
1	0	1	1:64	1:32
1	1	0	1:128	1:64
1	1	1	1:256	1:128

Bit 3	描 述
0	预分频器分配到 TMR0
1	预分频器分配到 WTD

Bit 4	描 述
0	外部时钟信号边沿上升时（从低电平到高电平），定时器加 1
1	外部时钟信号边沿下降时（从高电平到低电平），定时器加 1

Bit 5	描 述
0	TMR0 时钟源是（系统时钟/4）
1	TMR0 时钟源是 RTCC 输入



5.5 数据存储（寄存器和随机存储器）

数据存储由寄存器和随机存储器组成，地址映象如下表所示：

地址	描述
00	IAR
01	TMR0
02	PC
03	STATUS
04	BSR
05	PORTA
06	PORTB
07~1F	通用寄存器(RAM)

5.5.1 IAR: 间接寻址寄存器，它与BSR一起使用来访问物理地址。

5.5.2 TMR0: 8位累加定时器寄存器

5.5.3 PC: 程序计数器，10位计数器寄存器



5.5.4 STATUS: 状态寄存器

位	符号	描述	
0	C	进位位与借位位	
		加指令	减指令
		1: 从 MSB 进位 0: 无进位	1: 无借位 ^(注1) 0: 从MSB借位
1	DC	四位进位位与四位借位位	
		加指令	减指令
		1: 从低四位进位 0: 无低四位进位	1: 无低四位借位 0: 从低四位借位
2	Z	零标志位: 1: 逻辑操作结果是0 0: 逻辑操作结果非0	
3	PDB	掉电标记位: ^(注2) 1: 上电后或执行CLRWDT指令后, 结果为1 0: 执行SLEEP指令后, 结果为0	
4	TOB	溢出标志位: 1: 上电后或执行CLRWDT或SLEEP指令后, 结果为1 0: WDT时间溢出时, 结果为0	
5	SA0		页位置
		0 1	Page0 (000H~1FFH) Page1 (200H~3FFH)

<注1>: 减指令的执行是通过与减数的二进制补码相加来实现的, C=1代表结果是正数。进位与借位之间的关系如下表所示:

B0H-50H										50H-B0H									
	C	B7	B6	B5	B4	B3	B2	B1	B0		C	B7	B6	B5	B4	B3	B2	B1	B0
+		1	0	1	1	0	0	0	0			0	1	0	1	0	0	0	0
=	1	0	1	1	0	0	0	0	0		0	1	0	1	0	0	0	0	0



< 注 2 >: TOB 和 PDB 位是低有效, 可决定复位的不同原因。下表举例说明了不同复位后 TOB 和 PDB 的值。

TOB	PDB	复位结果
0	0	从睡眠模式 WDT 超时
0	1	从一般模式 WDT 超时
1	0	从睡眠模式 RESETB 输入“低”复位
1	1	上电复位
不变	不变	从一般模式 RESETB 输入“低”复位

5.5.5 BSR: Bank选择寄存器, 它和间接寻址寄存器一起间接地访问数据存储器。

5.5.6 A~B 口是可编程的 I/O 口, 复位时所有的 I/O 口都被置为输入模式。

5.6 复位

以下3种情况会引起系统复位:

5.6.1 上电

5.6.2 输入一个低电信号到RESETB

5.6.3 当WDTE标记允许及定时器溢出



5.7 所有RAM的复位条件

地址	名称	冷复位	热复位
N/A	Accumulator	xxxx xxxx	pppp pppp
N/A	IODIR	1111 1111	1111 1111
N/A	Select	--11 1111	--11 1111
00h	IAR	---- ----	---- ----
01h	TMR0	xxxx xxxx	pppp pppp
02h	PC	111 1111 1111	111 1111 1111
03h	STATUS	0001 1xxx	000# #ppp
04h	BSR	111x xxxx	111p pppp
05h	PORTA	0000 xxxx	0000 pppp
06h	PORTB	xxxx xxxx	pppp pppp
07h~1Fh	General Purpose RAM	xxxx xxxx	pppp pppp

<注> x: 未知的; p: 保存为原来的数值; #: 依据不同复位条件的数值;
 -: 不执行, 清“0”

5.8 唤醒功能

此芯片提供脚位信号触发唤醒功能, 当输入口有信号触发, 芯片将会从睡眠模式中返回。为了从睡眠模式中安全唤醒, 我们建议在进入睡眠模式前将输入脚位读为存储数据。编程举例如下所示:

```

MOVLA    FFh
IODIR    PORTB    ;//设置B口的0~7脚位为输入, 只有输入脚位会被唤醒
.....
MOV      PORTB,a ;//睡眠前存储输入脚位数据
SLEEP                    ;//如果不能执行读取指令, 则不能进入SLEEP模式
NOP                    ;//当芯片唤醒时增加NOP指令来延迟一会儿

```



6. 指令集

Mnemonic Operands	Instruction Code (Advance)	Cycles	Status Affected	OP-code
ADD M, m	(M)+(acc) → (M)	1	C, DC, Z	01 0101 1MMM MMMM
ADD M, a	(M)+(acc) → (acc)	1	C, DC, Z	01 0101 0MMM MMMM
AND M, m	(M) · (acc) → (M)	1	Z	01 0100 1MMM MMMM
AND M, a	(M) · (acc) → (acc)	1	Z	01 0100 0MMM MMMM
ANDLA I	Literal · (acc) → (acc)	1	Z	11 1001 iiiii iiiii
BC M, b0	Clear bit0 of (M)	1	None	00 1100 0MMM MMMM
BC M, b1	Clear bit1 of (M)	1	None	00 1100 1MMM MMMM
BC M, b2	Clear bit2 of (M)	1	None	00 1101 0MMM MMMM
BC M, b3	Clear bit3 of (M)	1	None	00 1101 1MMM MMMM
BC M, b4	Clear bit4 of (M)	1	None	00 1110 0MMM MMMM
BC M, b5	Clear bit5 of (M)	1	None	00 1110 1MMM MMMM
BC M, b6	Clear bit6 of (M)	1	None	00 1111 0MMM MMMM
BC M, b7	Clear bit7 of (M)	1	None	00 1111 1MMM MMMM
BS M, b0	Set bit0 of (M)	1	None	00 1000 0MMM MMMM
BS M, b1	Set bit1 of (M)	1	None	00 1000 1MMM MMMM
BS M, b2	Set bit2 of (M)	1	None	00 1001 0MMM MMMM
BS M, b3	Set bit3 of (M)	1	None	00 1001 1MMM MMMM
BS M, b4	Set bit4 of (M)	1	None	00 1010 0MMM MMMM
BS M, b5	Set bit5 of (M)	1	None	00 1010 1MMM MMMM
BS M, b6	Set bit6 of (M)	1	None	00 1011 0MMM MMMM
BS M, b7	Set bit7 of (M)	1	None	00 1011 1MMM MMMM
BTSC M, b0	If bit0 of (M) = 0, skip next instruction	1 + (skip)	None	00 0100 0MMM MMMM
BTSC M, b1	If bit1 of (M) = 0, skip next instruction	1 + (skip)	None	00 0100 1MMM MMMM
BTSC M, b2	If bit2 of (M) = 0, skip next instruction	1 + (skip)	None	00 0101 0MMM MMMM
BTSC M, b3	If bit3 of (M) = 0, skip next instruction	1 + (skip)	None	00 0101 1MMM MMMM
BTSC M, b4	If bit4 of (M) = 0, skip next instruction	1 + (skip)	None	00 0110 0MMM MMMM
BTSC M, b5	If bit5 of (M) = 0, skip next instruction	1 + (skip)	None	00 0110 1MMM MMMM
BTSC M, b6	If bit6 of (M) = 0, skip next instruction	1 + (skip)	None	00 0111 0MMM MMMM
BTSC M, b7	If bit7 of (M) = 0, skip next instruction	1 + (skip)	None	00 0111 1MMM MMMM



BTSS M, b0	If bit0 of (M) = 1, skip next instruction	1 + (skip)	None	00 0000 0MMM MMMM
BTSS M, b1	If bit1 of (M) = 1, skip next instruction	1 + (skip)	None	00 0000 1MMM MMMM
BTSS M, b2	If bit2 of (M) = 1, skip next instruction	1 + (skip)	None	00 0001 0MMM MMMM
BTSS M, b3	If bit3 of (M) = 1, skip next instruction	1 + (skip)	None	00 0001 1MMM MMMM
BTSS M, b4	If bit4 of (M) = 1, skip next instruction	1 + (skip)	None	00 0010 0MMM MMMM
BTSS M, b5	If bit5 of (M) = 1, skip next instruction	1 + (skip)	None	00 0010 1MMM MMMM
BTSS M, b6	If bit6 of (M) = 1, skip next instruction	1 + (skip)	None	00 0011 0MMM MMMM
BTSS M, b7	If bit7 of (M) = 1, skip next instruction	1 + (skip)	None	00 0011 1MMM MMMM
CLRA	Clear accumulator	1	Z	01 0001 0000 0000
CLR M	Clear memory M	1	Z	01 0001 1MMM MMMM
CLRWDT	Clear watch-dog register	1	TO, PO	01 0000 0000 0001
COM M, m	$\sim(M) \rightarrow (M)$	1	Z	01 0010 1MMM MMMM
COM M, a	$\sim(M) \rightarrow (\text{acc})$	1	Z	01 0010 0MMM MMMM
DEC M, m	Decrement M to M	1	Z	01 0110 1MMM MMMM
DEC M, a	$(M) - 1 \rightarrow (\text{acc})$	1	Z	01 0110 0MMM MMMM
DECSZ M, m	$(M) - 1 \rightarrow (M)$, skip if (M) = 0	1 + (skip)	None	01 0111 1MMM MMMM
DECSZ M, a	$(M) - 1 \rightarrow (\text{acc})$, skip if (M) = 0	1 + (skip)	None	01 0111 0MMM MMMM
INC M, m	$(M) + 1 \rightarrow (M)$	1	Z	01 1000 1MMM MMMM
INC M, a	$(M) + 1 \rightarrow (\text{acc})$	1	Z	01 1000 0MMM MMMM
INCSZ M, m	$(M) + 1 \rightarrow (M)$, skip if (M) = 0	1 + (skip)	None	01 1001 1MMM MMMM
INCSZ M, a	$(M) + 1 \rightarrow (\text{acc})$, skip if (M) = 0	1 + (skip)	None	01 1001 0MMM MMMM
IODIR M	Set i/o direction	1	None	01 0000 0000 0MMM
IOR M, m	$(M) \text{ ior } (\text{acc}) \rightarrow (M)$	1	Z	01 1111 1MMM MMMM
IOR M, a	$(M) \text{ ior } (\text{acc}) \rightarrow (\text{acc})$	1	Z	01 1111 0MMM MMMM
IORLA I	Literal ior (acc) \rightarrow (acc)	1	Z	11 0011 iiiii iiiii
LCALL I	Call subroutine. However, LCALL can addressing 2K address	2	None	10 0iii iiiii iiiii
LGOTO I	Go branch to any address	2	None	10 1iii iiiii iiiii
MOVAM m	Move data form acc to memory	1	None	01 0000 1MMM MMMM



MOVLA I	Move literal to accumulator	1	None	11 0001 iiiiiiii
MOV M, m	(M) → (M)	1	Z	01 0011 1MMM MMMM
MOV M, a	(M) → (acc)	1	Z	01 0011 0MMM MMMM
NOP	No operation	1	None	01 0000 0000 0000
RET	Return	2	None	11 1111 0111 1111
RETI	Return and enable INTM	2	None	11 1111 1111 1111
RETLA I	Return and move literal to accumulator	2	None	11 1100 iiiiiiii
RL M, m	Rotate left from m to itself	1	C	01 1100 1MMM MMMM
RL M, a	Rotate left from m to acc	1	C	01 1100 0MMM MMMM
RR M, m	Rotate right from m to itself	1	C	01 1110 1MMM MMMM
RR M, a	Rotate right from m to acc	1	C	01 1110 0MMM MMMM
SELECT	Set select register	1	None	01 0000 0000 0010
SLEEP	Enter sleep (saving) mode	1	TO, PO	01 0000 0000 0011
SUB M, m	(M) - (acc) → (M)	1	C, DC, Z	01 1010 1MMM MMMM
SUB M, a	(M) - (acc) → (acc)	1	C, DC, Z	01 1010 0MMM MMMM
SWAP M, m	Swap data from m to itself	1	None	01 1101 1MMM MMMM
SWAP M, a	Swap data from m to acc	1	None	01 1101 0MMM MMMM
XOR M, m	(M) xor (acc) → (M)	1	Z	01 1011 1MMM MMMM
XOR M, a	(M) xor (acc) → (acc)	1	Z	01 1011 0MMM MMMM
XORLA I	Literal xor (acc) → (acc)	1	Z	11 1000 iiiiiiii



7. 电气特性

7.1 绝对最大额定值

电源电压 Vss-0.3V to Vss+5.5V 存储温度 -50°C to 125°C
输入电压 Vss-0.3V to VDD+0.3V 工作温度 0°C to 70°C

7.2 直流电特性

Symbol	Parameter	Test Conditions		Min.	Typ.	Max.	Unit
		VDD	Conditions				
VDD	Operating Voltage	---		2.2		5.5	V
V _{DVT}	Detect Voltage	5V	Low Voltage Detector (I _{dd} = 3uA) Config bit6.bit5=00		3.5		V
		3V	Low Voltage Detector (I _{dd} = 1.5uA) Config bit6.bit5=10		2.1		V
V _{IL}	Input Low Voltage	5V	I/O Port			0.8	V
I _{DD1}	Standby Current	5V	WDT disable		1		uA
			WDT enable		10		
I _{IL}	Input Leakage Current	5V	Vin=VDD, VSS		1		uA
I _{DD1}	Standby Current		LV disable,WDT disable,		1		uA
			LV disable,WDT enable,		5		
			LV disable,WDT disable,		1		
			LV disable,WDT enable,		2		
I _{IL}	Input Leakage Current	5V	Vin=VDD, VSS		1		uA
			Vol=01V		35		
			Vol=1.5V		50		
R _{PUHI}	Pull_Hi Pin Resistor	5V	Set PortB input pin and Pull_Hi		60		KΩ
		3V	Set PortB input pin and Pull_Hi		150		



7.3 交流电特性

Symbol	Parameter	Test Conditions		Min	Typ	Max	Unit
		VDD	Conditions				
f _{sys1}	System Clock	5V	LS Crystal mode	32		200	Khz
		3V		32		200	
f _{sys2}	System Clock	5V	NT Crystal mode	0.2		10	Mhz
		3V		0.2		10	
f _{sys3}	System Clock	5V 3V	HS Crystal mode	10		20	Mhz
f _{sys4}	System Clock	5V	RC mode			6	Mhz
		3V		6			
T _{wdt}	Watchdog Timer	5V 3V			20 25		mS
T _{rht}	Reset Hold Time	5V 3V			20 25		mS

7.4 外部 RC 数据表

R value	C value	RC frequency	R connect to (VDD, OSC1)
4.9 M	0.1u (need)	32 Khz	电容器需要稳定的频率
250 K	0.1u (suggest)	455 Khz	
116 K	0.1u (suggest)	1 Mhz	
60 K	0.1u (suggest)	2 Mhz	
32 K	0.1u (suggest)	4 Mhz	
18 K	0.1u (suggest)	8 Mhz	
14 K	0.1u (suggest)	10 Mhz	



8. 封装尺寸

(a) 18 Pin DIP (300 mil)

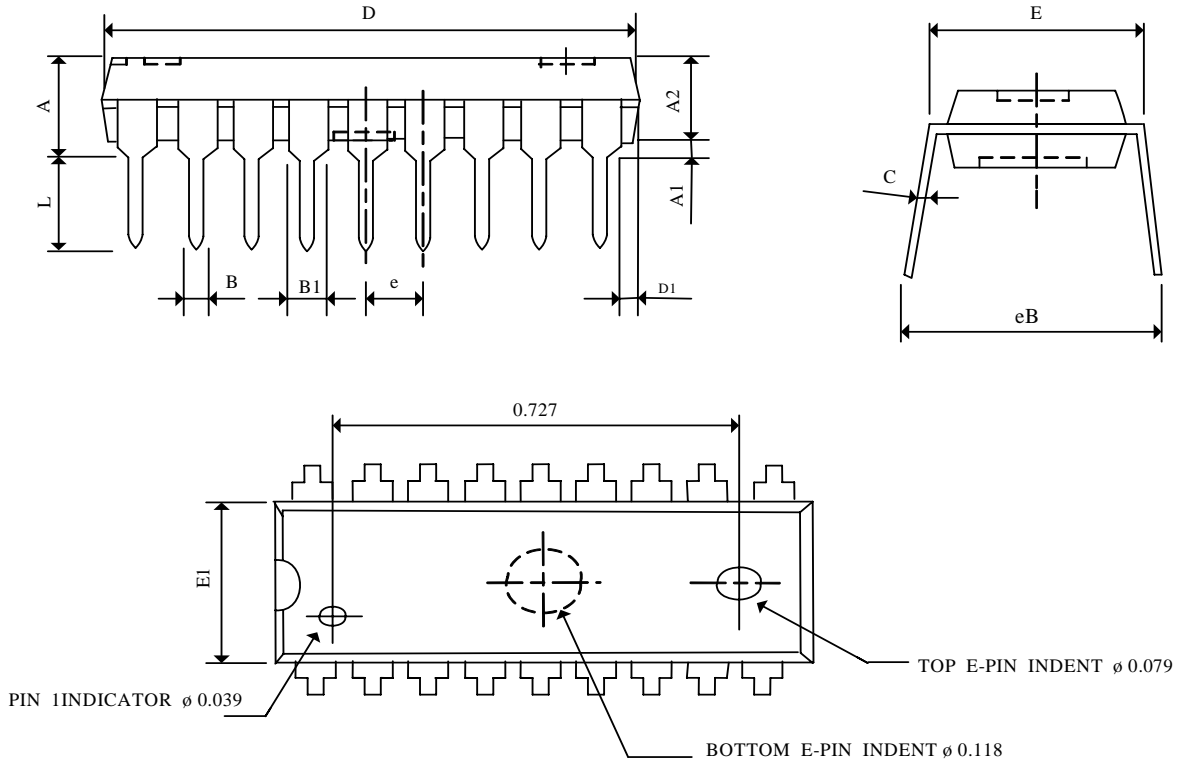

SYMBOLS	DIMENSIONS IN MILLIMETERS			DIMENSIONS IN INCHES		
	MIN	NOM	MAX	MIN	NOM	MAX
A	—	—	4.57	—	—	0.180
A1	0.38	—	—	0.015	—	—
A2	—	3.30	3.56	—	0.130	0.140
B	0.36	0.46	0.56	0.014	0.018	0.022
B1	1.27	1.52	1.78	0.050	0.060	0.070
C	0.20	0.25	0.33	0.008	0.010	0.013
D	22.71	22.96	23.11	0.894	0.904	0.910
D1	0.43	0.56	0.69	0.017	0.022	0.027
E	7.62	—	8.26	0.300	—	0.325
E1	6.40	6.50	6.65	0.252	0.256	0.262
e	—	2.54	—	—	0.100	—
L	3.18	—	—	0.125	—	—
eB	8.38	—	9.65	0.330	—	0.380



(b) 18 Pin SOP (300 mil)

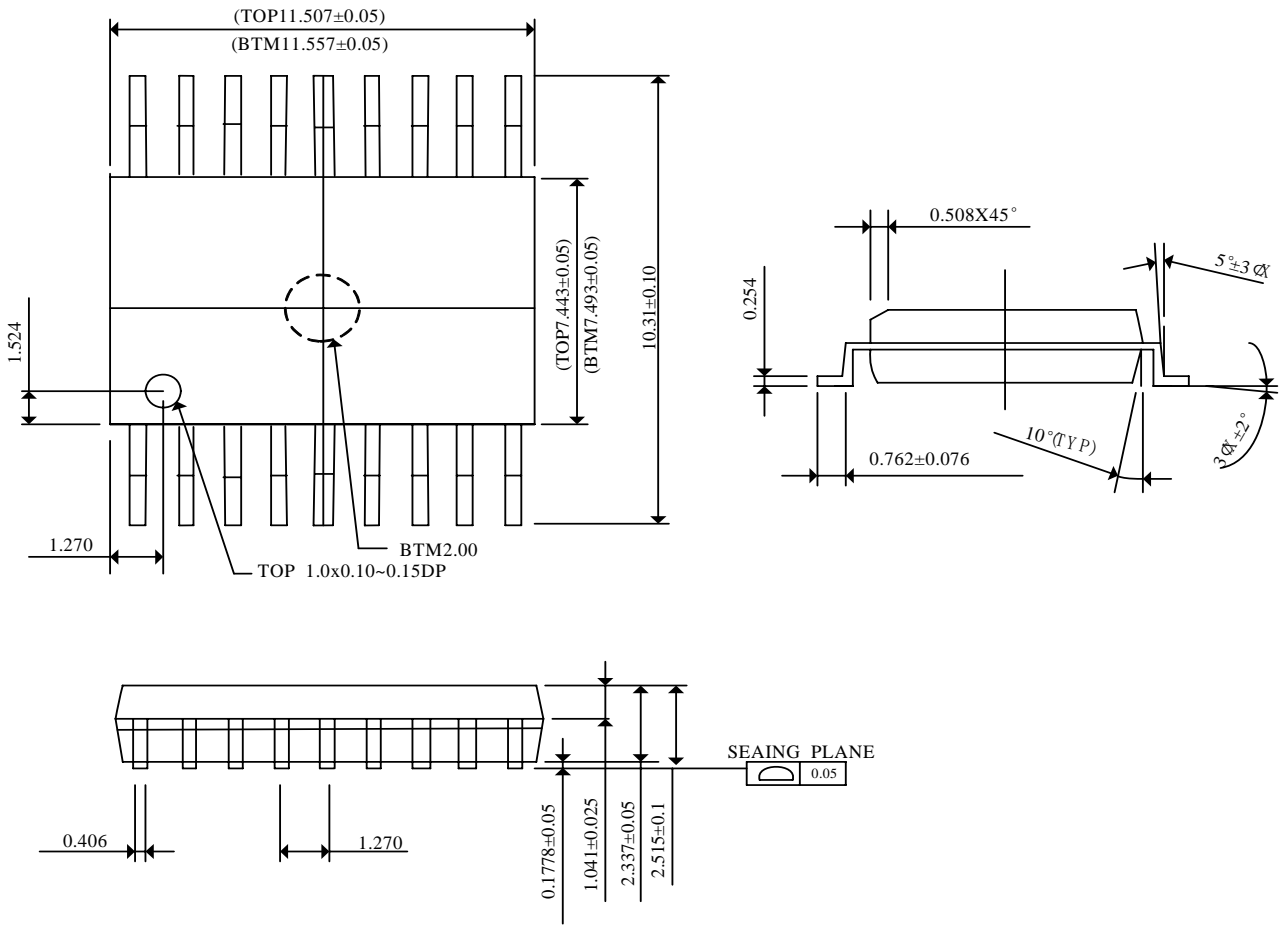



(c) 14 Pin DIP (300 mil)

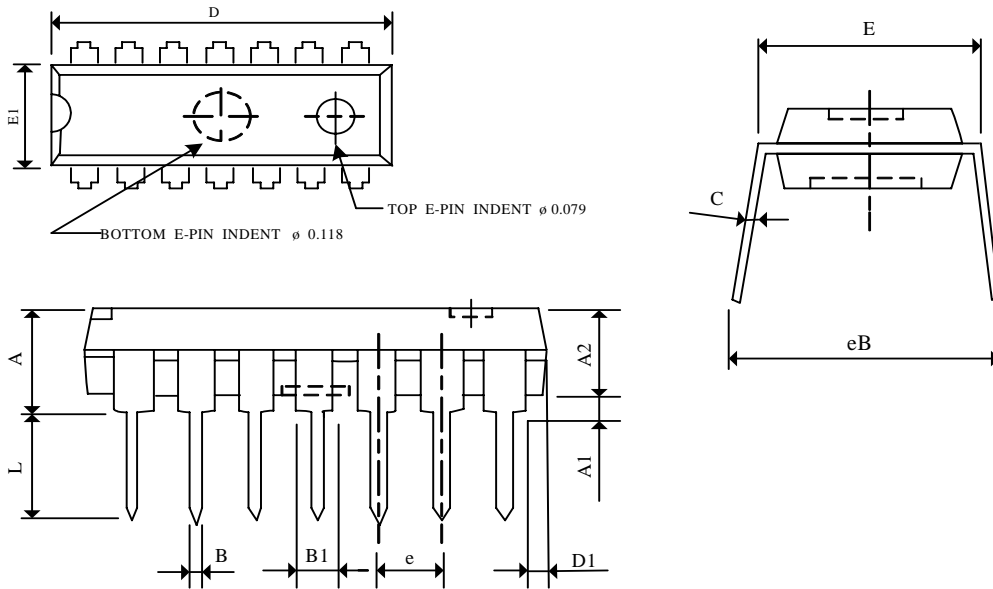

SYMBOLS	DIMENSIONS IN MILLIMETERS			DIMENSIONS IN INCHES		
	MIN	NOM	MAX	MIN	NOM	MAX
A	—	—	4.57	—	—	0.180
A1	0.38	—	—	0.015	—	—
A2	3.25	3.30	3.45	0.128	0.130	0.136
B	0.36	0.46	0.56	0.014	0.018	0.022
B1	1.27	1.52	1.78	0.050	0.060	0.070
C	0.20	0.25	0.33	0.008	0.010	0.013
D	18.90	19.15	19.30	0.744	0.754	0.760
D1	1.07	1.19	1.32	0.042	0.047	0.052
E	7.62	—	8.26	0.300	—	0.325
E1	6.35	6.50	6.65	0.250	0.256	0.262
e	—	2.54	—	—	0.100	—
L	3.18	—	—	0.125	—	—
eB	8.64	—	9.65	0.340	—	0.380



(d) 14 Pin SOP (150 mil)

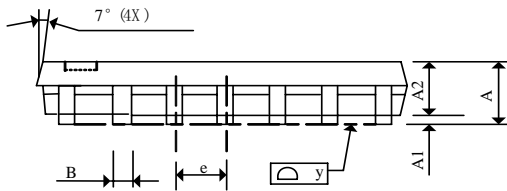
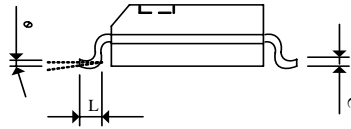
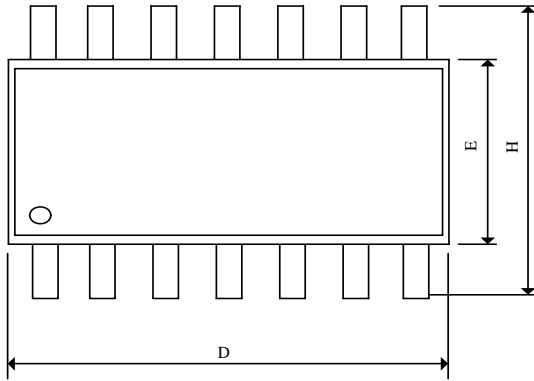

SYMBOLS	DIMENSIONS IN MILLIMETERS			DIMENSIONS IN INCHES		
	MIN	NOM	MAX	MIN	NOM	MAX
A	1.35	1.60	1.75	0.053	0.063	0.069
A1	0.10	—	0.25	0.004	—	0.010
A2	—	1.45	—	—	0.057	—
B	0.33	—	0.51	0.013	—	0.020
C	0.19	—	0.25	0.007	—	0.010
D	8.55	—	8.75	0.337	—	0.344
E	3.80	—	4.00	0.150	—	0.157
e	—	1.27	—	—	0.050	—
H	5.80	—	6.20	0.228	—	0.244
L	0.40	—	1.27	0.016	—	0.050
Y	—	—	0.10	—	—	0.004
θ	0°	—	8°	0°	—	8°